

Made in America

Lifetime Guarantee

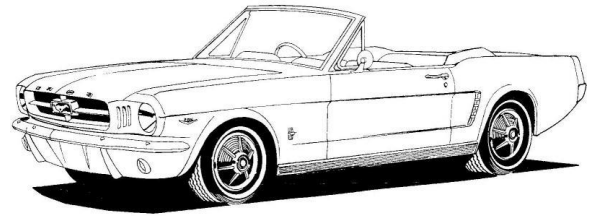

Thank you for purchasing this instrument from Intellitronix. We value our customers!

INSTALLATION GUIDE
Ford Mustang Digital Analog Dash Panel
Part Number: AP7001
Year Series: 1965 – 1966

*** Always disconnect the battery *before* attempting any electrical work on your vehicle. ***

KIT COMPONENTS

One (1) Digital Analog assemble: Speedo/Tach Combo, Fuel, Water Temp, Volt, and Oil pressure gauge *** Peel off protective covering from the front of the panel ***

One (1) Temperature Sending Unit (*S8013*) *** 1/8" NPT, 0-255 Deg., 1/2" NPT Bushing**

One (1) Pressure Sending Unit (*S8868*) *** 1/8" NPT, 0-100 PSI Oil Pressure**

One (1) Ford Speedometer Sensor (*S9024*)

Six (6) #6 X 1" Black Oxide sheet metal screws

DASH PANEL INSTALLATION INSTRUCTIONS

1. Remove all gauges from the stock bezel and housing.
2. Position the new dash panel into the stock gauge bezel (you will not reuse the factory housing).
3. Secure into place with the existing stock screws, spacers, and washers.

WIRING INSTRUCTIONS

Note: Automotive circuit connectors are the preferred method of connecting wires. However, you may solder if you prefer.

Note: LS Engines or any other computer-based engine systems most use provided sensors and install new wires to new sensors

Ground – Black--This is the main ground for the display system. A wire should be run from this board to the vehicle engine block for the best ground. Use 18 AWG or larger wire to ensure sufficient grounding. Proper vehicle grounding is extremely important for any gauges (or electronics) to operate correctly. The engine block should have heavy ground cables connected to the battery, frame, and firewall. Failure to properly ground the engine block, senders, or digital dash can cause incorrect or erratic operation.

Battery - Red--Connect the +12 Volt wire to constant +12V power from the battery power source from fuse panel. Using a 5-amp fuse or an inline 5-amp fuse holder Using 18 AWG wire.

Power – Pink--Connect the power terminal to accessory +12V power from the fuse panel or vehicle wiring harness. Using a 5-amp fuse or an inline 5-amp fuse holder. This terminal should have power when the key is on or in accessory position. Use 18 AWG wire to ensure the system receives a sufficient power feed.

Water – Blue - This gauge is incompatible with other sending units, so you must replace the existing water temperature sending unit with the included sender. **Do not** use Teflon tape or other sealer on the new sending unit's threads to avoid inaccurate readings. Connect the blue wire to the sending unit. For best results we suggest running a new wire.

Oil Pressure – Orange - Replace the existing oil pressure sending unit with the unit included with your gauge. The Orange wire will be wired to the S terminal on the sending unit. This gauge is incompatible with other sending units.

Oil Pressure – Ground Wire- From the G terminal on sender will be wired to ground on the engine block using 18 Ga wire to ensure proper ground!

Securely connect orange wire to S terminal

Securely connect black/orange wire to G terminal

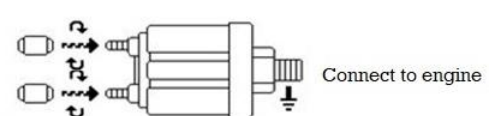

Dimmer – Purple Connect to the parking lights to dim the LEDs 50% when the headlights are on. However, ***DO NOT*** connect to the headlight rheostat control wire, or the dimming feature will not work properly and may cause damage to the Unit. This wire is looking for 12v power to turn on dimming feature.

Brake – Tan - Connect to the parking brake or wire from the dash to negative side of parking brake light switch. **NOTE:** If you are using a one wire switch you may need to switch to a two-wire switch. This wire is an optional wire some vehicles may not require

High-Beam – Brown - Connect the brown wire on the Dash unit to your high beam headlight circuit. This wire is powered on when the high beam is turned on and receives 12 volts.

Right Turn Signals - Grey with White strip 18-gauge wire is the - RIGHT turn signal

Left Turn Signals - Grey with Black strip 18-gauge wire is the - Left turn signal.

NOTE: Each wire is also labeled on the printed circuit board as 'LEFT' or 'RIGHT'. Connect each wire to its corresponding indicator circuit.

Voltage Gauge – This Gauge Requires no wire hookup. Volt Gauge is built into the dash panel and is powered by the main power and ground connection of the dash. It does have an Adjuster to fine tune the voltage. Note: you will need to adjust it before fully installing the dash



CABLE BUTTONS

Trip/Cal Button - Grey Cable Button or Push button on Dash - There are two grey wires connected to the push-button for the speedometer board. Mount the switch in a convenient location such as under the steering column so that you may easily reset your trip odometer or other speedometer functions.

Note: Before installing or Setting up you must know your Fuel sender OHMS Range to properly set Gauge up.





Fuel – Yellow The fuel gauge sending unit is not normally supplied because the display system can use the existing fuel level sending unit in the tank in most cases. If your wiring harness already has a single wire routed through the vehicle for the fuel sender, then it may be used. If using a wire from an external harness, make sure that the wire does not have power. Fuel senders reference their ground from the sender mounting plate. Connect the yellow wire to the factory sending unit. Be sure the toggle settings on the switch match those displayed on the panel, as illustrated. **NOTE: If the switch is on the back of the circuit board the position is UPSIDE DOWN!**
FORD FUEL DIP SWITCH

DIP SWIT – ONE ON - - - - DIP SWITCH TWO ON = 73 TO 10

DIP SWIT – ONE ON - - - - DIP SWITCH TWO OFF = 16 TO 158

DIP SWIT – ONE OFF - - - - DIP SWITCH TWO OFF = 240 TO 33

DIP SWIT – ONE OFF - - - - DIP SWITCH TWO ON = 22 TO 145

Fuel Selector Switch Position			
Manufacturer	Switch Position	Ohm Range (Empty to Full)	
FORD		73-10	ON 
FORD		16-158	
FORD		22-145	
FORD		240-33	

FUEL GAUGE TEST

The most common problem with our Fuel Gauge not working is the circuit is not complete. The easiest way to test for this is to use a voltmeter and test for continuity on wires going to fuel sender after disconnecting from gauge. If not disconnected it will give you a false reading. With wire disconnected from Fuel Gauge check for continuity to ground. Then test for OHMS to verify within range of fuel sender. If you don't have an accurate reading. Run a new ground wire to engine without this the Gauge will not work properly. **Note: Verify Ohm range of sender and match settings before cutting a wire or setting Dip switches for testing**

Tachometer – Green

If your vehicle has a **separate ignition coil**, connect the green wire to the **negative (-)** side of the coil – the wire that goes to the points or electronic ignition module.

To ensure that the ignition system does not interfere with any other dashboard functions, do not run the tachometer wire alongside any other sender or input wires. **Do not** use solid core spark plug wires with this dashboard system. Solid core ignition wires cause a large amount of electromagnetic and radio frequency interference which can disrupt the system's operation.

If your vehicle has a **GM HEI ignition**, connect to the terminal marked 'TACH', or, on some systems, a single white wire with a spade terminal.

If your vehicle has an **after-market ignition** – some systems will connect to the TACH output terminal.

If your vehicle has a **computer-controlled ignition** system, consult the service manual for the wire color and location for Tach signal output.

If your vehicle has a **magneto** system, connect the tach signal wire to the negative side of the coil. **Do not** connect the tach terminal to the positive (+ or high voltage) side of the ignition coil. Many tachometers, shift lights or RPM-activated switches will not read directly from a Magneto, so your installation may need a Magneto Signal Converter to function properly.

The default setting for the tachometer is for an 8-cylinder engine.

SPEEDOMETER (you have three methods for speedometer connection)

1.) Speedometer – White - (Factory sender with Powertrain Control Module) When using a LS engine swap, you will need to pick up the Speedometer signal wire from the PCM Pin 50 on the red connector. (This pin may Differ. Refer to your vehicles Pinout Chart for accuracy). Any other Computer based engine will need to use the PCM/ECM to run the speed signal for the Speedometer. (Consults Pinout Chart)

2.) Speedometer – White - (Factory two wire sender no PCM) - Most vehicles built after 1984 have an electronic transmission sender. If your vehicle is already equipped with an electronic transmission, then the electronic vehicle sender will usually have Two wires attached to it. One connects to the Signal wire on dash (we prefer this to be high output). The other wire (Low output) Ground at the Engine block. To find High and Low output wire color or pin location will need to be looked up by Vehicle vin or Model and year or (Consults Pinout Chart).

3.) Speedometer - White (Intellitronix Speed Sender) - Disconnect the mechanical speedometer cable from the transmission and insert the new electronic sensor into the transmission. This panel comes with a 3-wire sensor. If you are using this sensor, the **white** wire is the speed signal; connect this to the speed signal wire on your gauge. The **red** and **black** wires in the cable are switch power (12VDC) and ground, respectively.

NOTE:(Twist all Three wires together and this will provide an additional level of interference protection for signal wire.) The speed signal wire should not be routed alongside the tachometer, ignition, or any other high-current or high-voltage wires.

NOTE: The sensor you have received may need to have mount and/or O-ring changed to fit Correctly. You will also need to reuse speedometer gear from factory adaptor.

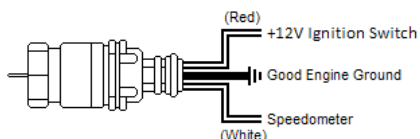

This may not look like correct sensor but it wires the same

Ford speed sender in kit

Modes

Push	Mode
Once	Tach /Speed Combo
Twice	Speed and Trip Odometer
Three	Speed and Odometer

To change settings:

The recall button on the speedometer operates as follows:
Once – cycles between Trip Mode and Odometer Mode.

While in Odometer Mode:

1. Hold LEFT to enter Recall/Setting Mode
2. ¼ Mile Recall
3. 60 Second Time Recall
4. CYL Selection
5. Odometer Setting
6. Calibration

CALIBRATION

Note: If using the unelectronic GPS Sending Unit (not included), the speedometer does not need to be calibrated.

Your unelectronic dash panel is equipped with our Digital Performance Speedometer, which has factory settings that are **pre-set with the industry standard setting of 8,000 pulses per mile to match your vehicles factory settings**. This electronic speedometer displays speed and includes an odometer, trip meter, high speed recall, 0-60 time, and quarter-mile elapsed time. It can be calibrated with the push-button to adjust the speedometer when you have **different tire sizes, wheel sizes, and gear ratios**.

The single push-button is used by a *quick tap* to toggle between odometer and trip meter. The microprocessor distinguishes between a *quick tap* and a *press and hold* which will reset the trip meter in trip mode or display performance data in odometer mode.

CALIBRATION

The Digital Performance Speedometer leaves the factory with a factory pre-set industry standard setting of 8,000 pulses per mile. You should **not have to recalibrate your speedometer, unless you have changed the original tire size or the rear end gear ratio**.

NOTE: DO NOT attempt to recalibrate your speedometer until after it is working properly, and you have determined that the speed is consistently incorrect. The calibration procedure will NOT correct a faulty installation or improper wiring.

WARNING: If, while in 'CAL' mode, **you do not move the vehicle but press the button again**, the microprocessor will NOT have received any data and the unit will display 'Err' and will revert to the factory settings. At a minimum, drive some distance and return to the start if necessary. If you miss stopping the display at 'CAL', simply repeat the steps.

To calibrate:

1. **Locate a measured mile or kilometer where you can safely start and stop your vehicle.** By running the vehicle over this measured distance, the speedometer will learn the number of pulses outputted by the speedometer sensor during a specific measured distance. It will then use this acquired data to calibrate itself for accurate reading. There is a small recall pushbutton in the center of the panel used to calibrate and read all of the data stored in the speedometer. After installing your speedometer according to the wiring instructions, when the ignition is on it should immediately display the default screen of **0 MPH**, if the vehicle is not moving.

NOTE: You will then need to drive your vehicle to the predetermined measured mile. During this trip, the speedometer should read something other than 0 MPH. If it does not change, return and locate the problem before continuing. Otherwise, proceed with the calibration.

2. Stop at the beginning of the measured mile with your vehicle running and in odometer mode (NOT trip mode), press and hold the push-button until the odometer displays 'HI-SP'. On its own, the gauge will then cycle through the recorded performance in the following order: '0 - 60', '1/4', 'ODO', and 'CAL'.
3. While 'CAL' is displayed, quickly *tap* the push-button once. This will put the speedometer in Program Mode. If you did not tap while 'CAL' is displayed, the pulses per mile will be displayed on the odometer and the display will go back to MPH mode. Otherwise, you will now see 'CAL' displayed along with the number '0'. This indicates that the microprocessor is now ready for calibration.
4. When you are ready, begin driving on the metered mile. You will notice that the reading will start counting up. The odometer will begin to display the incoming pulse count. Drive the vehicle through the measured mile (speed is not important, only the distance traveled).
5. At the end of the mile, stop and press the push-button again. The odometer will now display the new number of speedometer pulses that were registered over the distance. The odometer will continue to display the pulse reading for a few seconds. Once it reverts to the default mode, you have successfully calibrated your speedometer.

Setting the Odometer

While scrolling through 'CAL' mode you will see 'd' appear. This will allow you to enter the vehicle's actual mileage. Press the trip button again at this point and you will enter the odometer set up mode. Press quickly to change the number of the digit on the right. Press and hold to advance to the next digit. Do this for all 5 digits.

For Example: To enter the mileage 23456 into the odometer, at the 'ODO' prompt, tap the small black button (quickly) two times, until the number 2 is displayed. Then press and hold the button until the numbers 20 are displayed. Tap the button 3 times until 23 is displayed. Press and hold the button until 230 is displayed and continue in this manner until 23456 is displayed. The speedometer will advance to the home screen, five seconds after the last number is entered.

Recording and Viewing Performance Data

Follow these steps to record and recall Performance Data (high speed, ¼ mile ET, and 0- 60 time):

1. Before each run, your car must be at a complete stop at the starting position. Press and hold the push-button as it cycles through the performance data. At the end, the odometer will reset, and all performance data will be cleared. This will not affect your stored calibration value or the odometer reading.
2. Press the push-button until 'HI-SP' is displayed. The gauge will automatically cycle through the performance data.
3. Start the run, pass, session, etc., as mentioned above.
4. When finished, repeat Step 2 to view the data gathered from the run. While stopped, you can view this data as often as you wish. However, once it finishes scrolling one time, the memory is ready to record new data and will begin recording again once the vehicle starts to move. The highest speed measured over multiple runs will be retained in memory.

Made in America

Lifetime Guarantee



Technical Support

Monday – Friday

9am to 5 pm EST

(440) 359 7200 ext 109

support@intellitronix.com

CHECK OUT THE **SUPPORT** PAGE AT

www.intellitronix.com

This product carries a limited Lifetime Warranty.

This warranty is limited to replacement or repair of the unit at the discretion of Intellitronix.